

# TECHTROL & BILGE LEVEL SWITCH - TBS

It is a rugged and portable submersible level switch, for broad range of liquids under turbulence and subject to mechanical load due to contamination of debris in liquids.

## Salient Features:

- Easy installation through mounting bracket
- Reliable performance under most demanding conditions
- IP 68 protection
- IRS class type approved

## Construction & Operation :

It consists of a float switch enclosed in heavy duty slosh shield to protect switch operation from suspended particles and turbulence. Float follows liquid level & magnetically actuates the reed switch at defined position. The switch is provided with a test lever (In Situ Test) to manually check the switch functioning.

## Installation & Wiring :

It is mounted inside the tank at desired position through an extended cable and mounting bracket. The level switch can be wired directly to operate electric loads like annunciation, mimic indication, PLC, which match the low switching capacity of reed contacts. However for higher loads, use of Techtrol Level Controller is recommended. For marine applications, it is used for high level switching, however it is used for low level switching in many industrial applications.



**Schematic**

**Fig.-1**

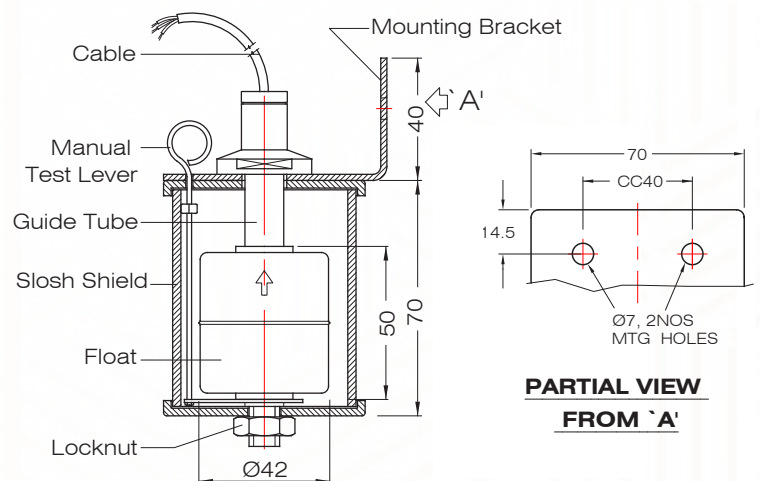

# Specifications

- Guide Tube : SS316
- Float : SS316 x 41dia
- Slosh Shield : SS316 with perforations
- Mounting Bracket : SS316 wall mounted type
- Manual Test Lever : SS304
- Termination : Epoxy potted extended cable
- Cable : 3 core x 0.75mm<sup>2</sup> multistrand PVC insulated & sheathed
- Cable extension : 2 or 10 or 15 mtrs
- Switch Type : Hermetically sealed reed contacts
- Contact Rating : 60VA (SPDT)
- Max. Sw. Voltage : 230 VAC
- Max. Sw. Current : 1A
- Switch Differential : 3~5mm
- Max. Temperature : 100°C
- Test Pressure : 10 Kg/cm<sup>2</sup>
- Min. Liquid SG : 0.8
- Ingress Protection : IP 68

# Applications / Services :

Raw, Fresh Water in Marine Bilge Wells, Sump, Storage Tanks, Reserviors, Solvent Recovery System and Hydraulic, Diesel, Lube Oil Consol Systems.

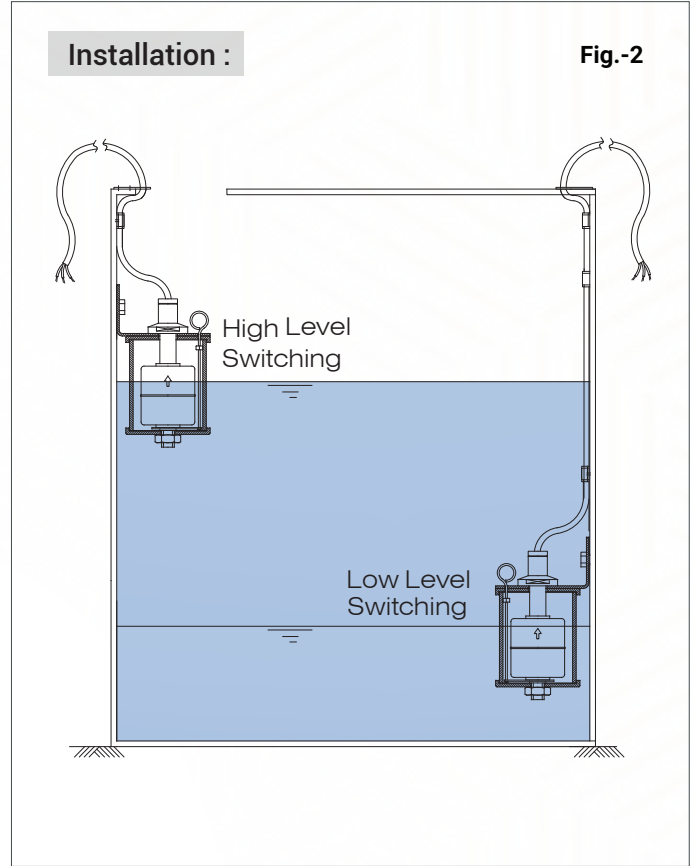

# Ordering Information :

- TBS - 2 ( 2 mtrs extended cable )
- TBS - 10 ( 10 mtrs extended cable )
- TBS - 15 ( 15 mtrs extended cable )

## PUNE TECHTROL PVT LTD

Regd. & Sales: S-18, MIDC Bhosari, Pune - 411026, India  
+91-20-66342900 | ho@punetechtrol.com

Works: J-52/7, MIDC Bhosari, Pune - 411026, India  
+91-20-67313600 | www.punetechtrol.com

