



## RS-12

### Pt100 - Simulator

Masibus RS-12 is a high precision Simulator for the simulation of Pt100 resistance thermometers. RS-12 covers the general operating range of Pt100 thermometers with 12 calibration points. The Simulator is small in size, rugged and easy to use and it has been especially designed for field use.

Since the output is a purely passive resistance, it can operate with all types of Pt100 measuring equipments, including the live systems using pulsed, or interrupted excitation current.

The precision Pt100 simulator is used wherever measuring instruments or controlling systems have to be tested or calibrated with great precision.

A distinctive feature of this simulator is their simple operation. The resistance values required for simulation are directly set in °C. There is no need to use tables.

#### Features

- Direct Temperature output 12 Switched Steps
- < 0.3 °C Accuracy
- Quick Check Switch BOX
- Allows 2, 3 or 4 wire connections
- Compact Size

#### Applications

- Food Industry, Medical Science
- Simulates RTD's in all types of instruments, such as transmitters, controllers and data acquisition, process control, lab equipment etc.
- For Maintenance & trouble shooting

# TECHNICAL SPECIFICATIONS

Specification		Table-1 (ITS 90)			
Temperature Range	12 set temperature values	<b>Adjustable Temperature Values</b>			
Accuracy	< 0.3 °C	-150°C	- 50°C	0°C	50°C
Temperature	20 ppm / °C	100°C	200°C	300°C	400°C
Coefficient		500°C	600°C	700°C	800°C
Allowable Excitation Current	0 to 15 milliamps steady or intermittent				
Physical					
Dimension (in mm)	50 (H) x135.4 (W) x 66.5(D)				
Enclosure material	Extruded Aluminum				
Protection	IP40				
Weight	<400 grams				
Terminals	4 nos, 4mm safety sockets				
Environment					
Operating Temperature	0 to 55 °C				
Storage Temperature	-20 to 70 °C				
Humidity	30 to 90 % RH				

## CONNECTION DETAILS

Example of application: Calibration of a controller

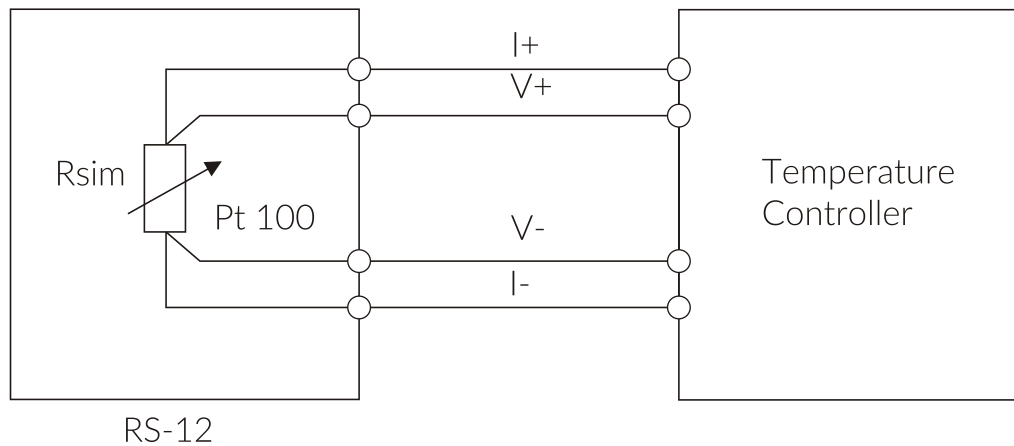

## ORDERING CODE

Model  
RS-12

- Comes with factory calibration certificate along with supply (Traceable to National/ International Standard)
- Calibration certificate from NABL Certified Lab (ISO: 17025) can be provided upon request - Please Contact Factory

## ACCESSORIES (STANDARD)

- Patch Cords RED (1 end Crocodile pin other end 4mm pin) - 2 nos
- Patch Cords BLACK (1 end Crocodile pin other end 4mm pin) - 2 nos
- Patch Cords (PC-3 RED) (Both End 4mm pin) - 2 nos
- Patch Cords (PC-3 BLACK) (Both End 4mm pin) - 2 nos